



Active Components Pump Laser Modules

Preliminary DATASHEET

Key Features

Operating Power up to 400mW

Ultra-Low Power Consumption

Operating Temperature from -5 to 70°C

Wavelength stabilization with FBG on PMF pigtail

Integrated Thermo-Electric Cooler, Thermistor

Telcordia GR-468-CORE qualified

RoHs 6/6

Applications

Raman Amplifier

For more info

Please contact us at:

North America: 514.748.4848
888.922.1044

Europe & Asia: +33 (0) 1 69 80 58 33
or via e-mail at sales@3spgroup.com

1943 RAM

Up to 400mW FBG Stabilized 14xx nm Pump Laser Module Ultra-Low Power Consumption

The 1943RAM is a new generation of Ultra-Low Power Consumption 14xx nm pump module designed for Raman amplification powered by an in-house chip technology leading to outstanding level of performance, power consumption and reliability.

Low Profile 14-pin butterfly modules are available with operating powers of 250, 360 & 400mW over a wavelength range from 1420nm to 1500nm and an extended case temperature range from -5 to 70°C. They incorporate a thermoelectric cooler (TEC), a precision NTC.

The wavelength is "locked" utilizing a Fiber Bragg Grating (FBG) located in a single mode Polarization Maintaining Fiber (PMF).

The module meets Telcordia™ GR-468-Core requirements for hermetic 14xx nm pump modules.

1943 RAM is offered in two versions: one without Monitoring Photo-Diode (MPD). The second one with an "On/Off" MPD

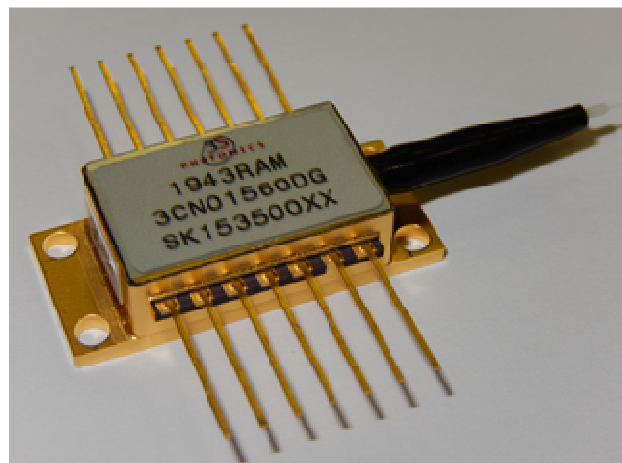

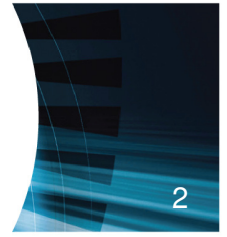
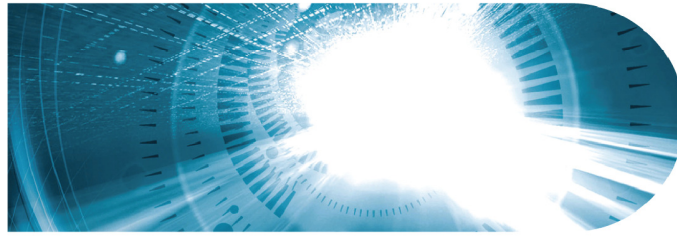

ELECTRO-OPTICAL CHARACTERISTICS (1)

The following parameters are specified Beginning of Life (BOL) for $T_{\text{SUBMOUNT}} = 40^\circ\text{C}$, $T_{\text{case}} = -5$ to 70°C , $P_{\text{op}} = P_{\text{nom}}$, unless otherwise stated.

| Parameters | Conditions | Symbol | Min | Typ | Max | Unit |
|------------------------------------------------|----------------------------------------------------------------------------|---------------------------------------|------|------|-----------------------------|----------------------|
| PUMP LASER | | | | | | |
| Threshold current (1) | - | I_{th} | - | - | 220 | mA |
| Forward current @ P_{nom} | $P_{\text{nom}} = 250\text{mW}$ | I_{op} | - | - | 1240 | mA |
| | $P_{\text{nom}} = 360\text{mW}$ | | - | - | 1490 | mA |
| | $P_{\text{nom}} = 400\text{mW}$ | | - | - | 1650 | mA |
| Operating current (End of Life) | $P_{\text{nom}} = 250, 360 \text{ \& } 400 \text{ mW}$ | $I_{\text{op EOL}}$ | - | - | $1.15 \times I_{\text{op}}$ | mA |
| Forward voltage | $P_{\text{nom}} = 250\text{mW}$ | $V_{\text{nom EOL}}$ | - | - | 1.64 | V |
| | $P_{\text{nom}} = 360\text{mW}$ | | - | - | 1.75 | V |
| | $P_{\text{nom}} = 400\text{mW}$ | | - | - | 1.85 | V |
| Minimum Operating Power | | P_{min} | 75 | | | mW |
| Target wavelength (in vacuum) | $P_{\text{nom}} \text{ \& } T_{\text{FBG}} = 25^\circ\text{C}$ | λ_t | 1420 | - | 1500 | nm |
| Center wavelength | $P_{\text{nom}},$ $T_{\text{case}} = T_{\text{FBG}} = 25^\circ\text{C}$ | λ_c | | | ± 0.5 | nm |
| Spectral Bandwidth RMS | $P_{\text{op}}, \text{ RMS}$ | $\Delta\lambda_{\text{FWHM}}$ | - | | 2 | nm |
| Power in band ($\lambda_t \pm 2\text{nm}$) | $I(100\text{mW}) < I < I_{\text{op}}$ | P_{band} | 80 | - | - | % |
| Polarization Extinction Ratio | P_{nom} | PER | 13 | - | - | dB |
| Relative Intensity Noise | 100kHz-1GHz | RIN | | | -105 | dB/Hz |
| Side Mode Suppression Ratio | P_{nom} | SMSR | 20 | - | - | dB |
| | P_{min} | | 10 | | | dB |
| Center wavelength variation vs FBG Temperature | | $\Delta\lambda/\Delta T_{\text{FBG}}$ | - | 0.01 | 0.02 | nm/ $^\circ\text{C}$ |

(1) I_{th} is the intersection point with the x-axis of a linear fit of the P(I) curve between 15 mW and 50 mW

1943RAM

Up to 400 mW
FBG Stabilized 14xx nm
Pump Laser Module

3SPTechnologies
Source of Smart Solutions

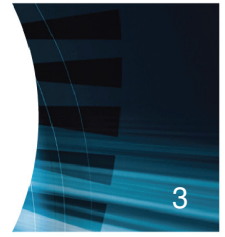
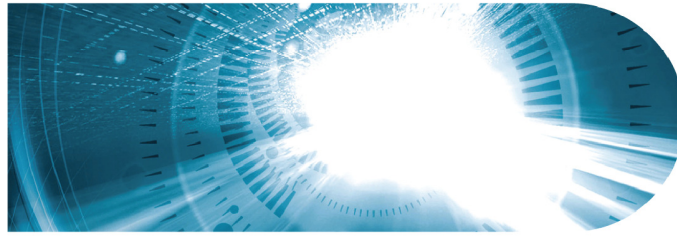

3

ELECTRO-OPTICAL CHARACTERISTICS (2)

The following parameters are specified BOL for $T_{\text{SUBMOUNT}} = 40^\circ\text{C}$, $T_{\text{case}} = -5$ to 70°C , $P_{\text{op}} = P_{\text{nom}}$, unless otherwise stated.

| Parameters | Conditions | Symbol | Min | Typ | Max | Unit |
|---------------------------------|----------------------------------------------------------------------|------------------|------|-----|------|------------------|
| MONITOR PHOTO-DIODE (2) | | | | | | |
| Monitor dark current | $V_{r,PD}=5V$ | I_d | - | - | 300 | nA |
| Monitor diode capacitance | $V_{r,PD}=5V, 1\text{MHz}$ | C_{MPD} | - | - | 20 | pF |
| Monitor Current | $V_{r,PD}=5V, 1\text{MHz}$ | I_{MPD} | - | - | 10 | mA |
| THERMO-ELECTRICAL COOLER | | | | | | |
| Cooling capacity | | ΔT_{TEC} | | | 30 | $^\circ\text{C}$ |
| TEC voltage (EOL) | $P_{\text{nom}} = 250\text{mW} @ T_{\text{case}} = 70^\circ\text{C}$ | $V_{TEC, EOL}$ | | | 1.95 | V |
| | $P_{\text{nom}} = 360\text{mW} @ T_{\text{case}} = 70^\circ\text{C}$ | | | | 2.16 | V |
| | $P_{\text{nom}} = 400\text{mW} @ T_{\text{case}} = 70^\circ\text{C}$ | | | | 2.53 | V |
| TEC current (EOL) | $P_{\text{nom}} = 250\text{mW} @ T_{\text{case}} = 70^\circ\text{C}$ | $I_{TEC, EOL}$ | | | 0.93 | A |
| | $P_{\text{nom}} = 360\text{mW} @ T_{\text{case}} = 70^\circ\text{C}$ | | | | 1.06 | A |
| | $P_{\text{nom}} = 400\text{mW} @ T_{\text{case}} = 70^\circ\text{C}$ | | | | 1.28 | A |
| Total Power consumption | $P_{\text{nom}} = 250\text{mW} @ T_{\text{case}} = 70^\circ\text{C}$ | $P_{TEC, EOL}$ | | | 4.0 | W |
| | $P_{\text{nom}} = 360\text{mW} @ T_{\text{case}} = 70^\circ\text{C}$ | | | | 4.9 | W |
| | $P_{\text{nom}} = 400\text{mW} @ T_{\text{case}} = 70^\circ\text{C}$ | | | | 6.5 | W |
| THERMISTOR | | | | | | |
| Thermistor Resistance | $T_{\text{submount}} = 25^\circ\text{C}$ | R_{th} | 9.5 | 10 | 10.5 | $k\Omega$ |
| | $T_{\text{submount}} = 40^\circ\text{C}$ | | 5.0 | | 5.6 | |
| Thermistor β Constant | | T_C | 3700 | - | 4100 | K |

(2) For Pump with On-Off MPD

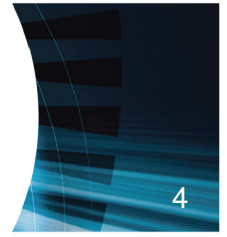
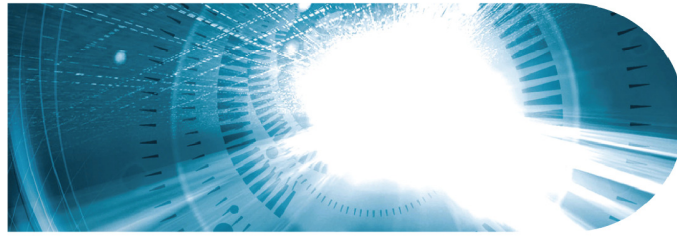

ABSOLUTE MAXIMUM RATINGS

Exposing this device to stresses and conditions above those listed in this section could cause permanent damage and affect reliability. The device is not meant to operate outside the operational limits described in previous section at any length of time.

| Parameter Conditions | Symbol | Min | Max | Unit |
|---------------------------------------------------------|-----------------|-----|------|------|
| Storage temperature (2000h) | T_{stg} | -40 | 85 | °C |
| Operating temperature ($T_{submount} = 40\text{°C}$)* | T_{op} | -5 | 70 | °C |
| Lead soldering temperature (10s maximum) | | - | 280 | °C |
| LD forward drive current | $I_{f,max}$ | - | 2000 | mA |
| LD reverse voltage | $V_{r,max}$ | - | 2 | V |
| LD Fwd Current | I_{rev} | - | 10 | μA |
| TEC voltage, Cooler mode | $V_{TEC,C,max}$ | - | 4.2 | V |
| TEC current, Cooler mode | $I_{TEC,C,max}$ | - | 2.0 | A |
| ESD damage** | V_{ESD} | - | 500 | V |
| Mounting torque | | - | 150 | mNm |
| Fiber temperature | | -40 | 85 | °C |
| Fiber bend radius | | 20 | - | mm |
| Axial pull force (1x 1min) | | - | 5 | N |
| PD Reverse voltage*** | $V_{r,PD}$ | - | 20 | V |
| PD forward current*** | $I_{f,PD}$ | - | 15 | mA |

* No cold start. TEC will be turned-on first.

** Human Body model, C= 100pF, R= 1.5kΩ

*** For Pump with On-Off MPD

FIBER PIGTAIL CHARACTERISTICS

| Parameter | Note | Min | Typ | Max | Unit |
|-----------------------------------------|--------------------------------------------|---------------------------------|-----|------|---------|
| Fiber type | | Corning PM15-U25A Specification | | | |
| Cut-off wavelength | | 1290 | | 1410 | nm |
| Extinction Ratio | | | 30 | | dB/100m |
| Mode field diameter | @1550nm | 9.5 | | 11.5 | μm |
| UV Coating diameter | (except along grating) | 230 | 245 | 260 | μm |
| Cladding diameter | | 122 | 125 | 128 | μm |
| FBG recoat diameter | | 260 | 295 | 400 | μm |
| FBG position to module | Module to center of FBG | - | 2.5 | - | m |
| FBG position to end pigtail | Edge of FBG recoat to end pigtail distance | 0.5 | - | - | m |
| Fiber bend radius | | 20 | - | - | mm |
| Splice distance from package (Optional) | | 0,3 | - | - | m |
| Pigtail length | | - | 3.4 | - | m |
| Polarization State | Aligned parallel to the slow axis | | | | |

1943RAM

Up to 400 mW
FBG Stabilized 14xx nm
Pump Laser Module

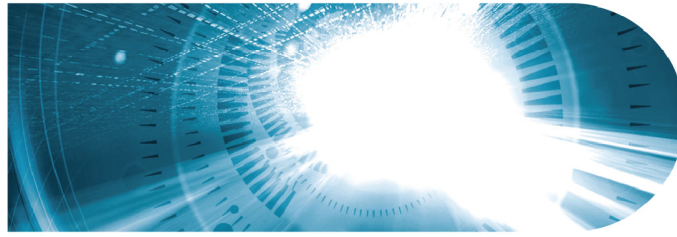

MECHANICAL DETAILS

Dimensions are in mm.

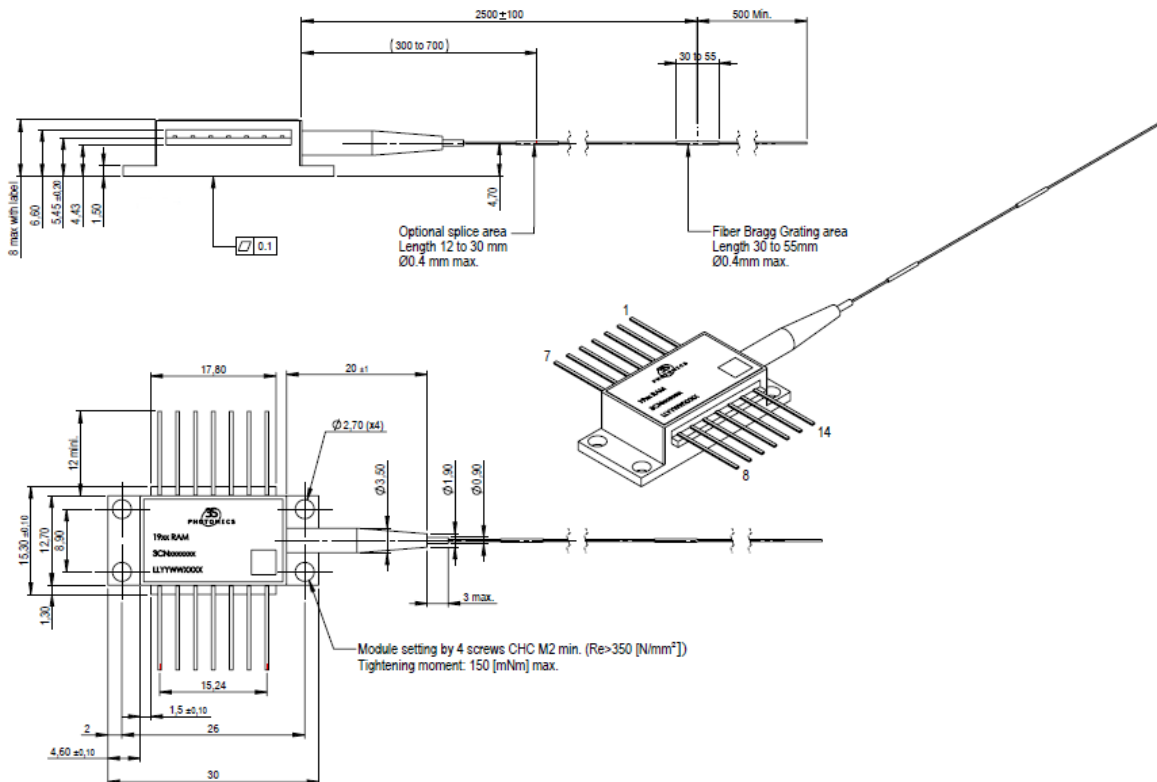

PIN ASSIGNMENT

| N° | Description (With On-Off MPD) | N° | Description |
|----|-------------------------------|----|-------------------------|
| 1 | TEC (+) | 14 | TEC (-) |
| 2 | Thermistor (TS) | 13 | Ground |
| 3 | PD Anode (+) | 12 | No connect |
| 4 | PD Cathode (-) | 11 | Laser Diode Cathode (-) |
| 5 | Thermistor (TS) | 10 | Laser Diode Anode (+) |
| 6 | No connect | 9 | No connect |
| 7 | No connect | 8 | No connect |

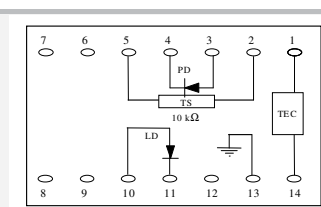

| N° | Description (without MPD) | N° | Description |
|----|---------------------------|----|-------------------------|
| 1 | TEC (+) | 14 | TEC (-) |
| 2 | Thermistor (TS) | 13 | Ground |
| 3 | No connect | 12 | No connect |
| 4 | No connect | 11 | Laser Diode Cathode (-) |
| 5 | Thermistor (TS) | 10 | Laser Diode Anode (+) |
| 6 | No connect | 9 | No connect |
| 7 | No connect | 8 | No connect |

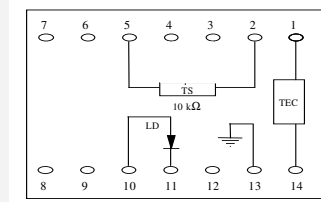

TOTALLY FLOATING PIN-OUT

1943RAM

Up to 400 mW
FBG Stabilized 14xx nm
Pump Laser Module

3SPTechnologies
Source of Smart Solutions

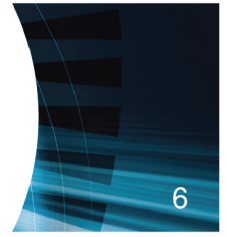
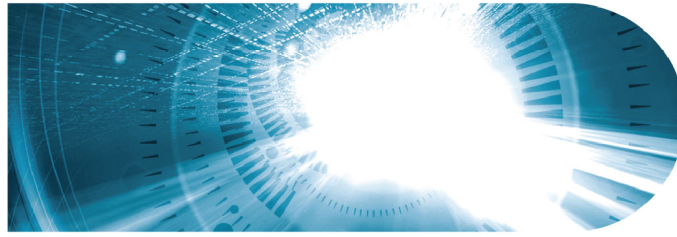

6

LASER SAFETY INFORMATION

This laser module emits invisible light. Take appropriate precautions to prevent undue exposure to naked eye when module is in operation. This product is classified Class 4 Laser Product according to IEC-60825-1.

HANDLING

This product is sensitive to modules. Handle the module by its package only. Never hold it by its pigtail. Care should be taken to avoid supply transient currents and voltages. Drive voltage above the maximum specified in absolute maximum rating section electrostatic discharge and should not be handled except at a static free workstation. Take precautions to prevent ESD; use wrist straps, grounded work surfaces and recognized anti-static techniques when handling the product may cause permanent damage to the device.

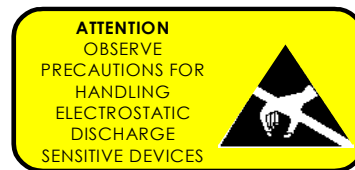

APPLICATION NOTE

In order to prevent any mishandling, misuse, neglect or accident, it is highly recommended to read and follow the instructions detailed in the application note:

[RCL IMA APN 000 00007 "Handling, Mounting, Testing and Operating Cooled 14-pin Butterfly Laser Pumps"](#)

1943RAM

Up to 400 mW
FBG Stabilized 14xx nm
Pump Laser Module

3SPTechnologies
Source of Smart Solutions

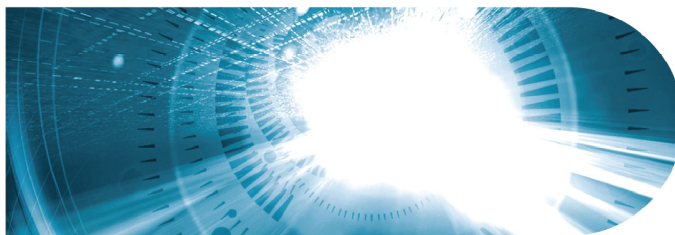

ORDERING INFORMATION

1943RAM pump product family

| | Operating Power | Operating wavelength (see Wavelength table) | 3SP Part Number |
|-------------------------|-----------------|------------------------------------------------|-----------------|
| Version without. MPD | 250mW | ## | 3CN01545## |
| | 360mW | ## | 3CN01556## |
| | 400mW | ## | 3CN01560## |
| Version with On-Off MPD | 250mW | ## | 3CN01714## |
| | 360mW | ## | 3CN01725## |
| | 400mW | ## | 3CN01729## |

refers to wavelength table below.

3SP Technologies can also develop custom products to meet a wide range of technical requirements.
Other wavelength can be offered upon request
Please contact our Sales Manager for details.

CONTACT INFORMATION

Europe & Asia: +33 (0) 169 805 833
North America: +1 514 748 4848
+1 888 922 1044

sales@3spgroup.com
www.3sptechnologies.com

IMPORTANT NOTICE

Information in this document is typical and must be specifically confirmed in writing by your supplier before it becomes applicable to any order or contract.

Information is subject to change without notice.

©2016 3SP Technologies S.A.S.



1943RAM

Up to 400 mW
FBG Stabilized 14xx nm
Pump Laser Module

3SPTechnologies
Source of Smart Solutions

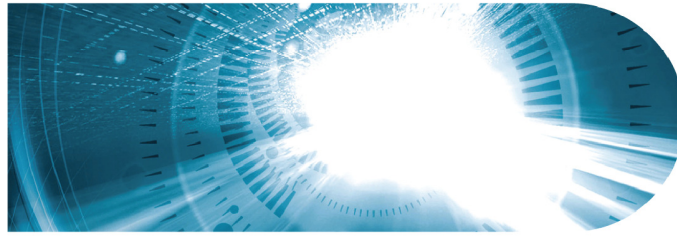

8

WAVELENGTH TABLE

| Lambda (nm) | ## |
|-------------|----|
| 1420,00 | CY |
| 1421,00 | DA |
| 1422,00 | DC |
| 1423,00 | DE |
| 1424,00 | DG |
| 1425,00 | DJ |
| 1426,00 | DL |
| 1427,00 | DN |
| 1428,00 | DQ |
| 1429,00 | DS |
| 1430,00 | DU |
| 1431,00 | DW |
| 1432,00 | DY |
| 1433,00 | EA |
| 1434,00 | EC |
| 1435,00 | EE |
| 1436,00 | EG |
| 1437,00 | EJ |
| 1438,00 | EL |
| 1439,00 | EN |
| 1440,00 | EQ |
| 1441,00 | ES |
| 1442,00 | EU |
| 1443,00 | EW |
| 1444,00 | EY |
| 1445,00 | FA |
| 1446,00 | FC |
| 1447,00 | FE |
| 1448,00 | FG |
| 1449,00 | FJ |
| 1450,00 | FL |
| 1451,00 | FN |
| 1452,00 | FQ |
| 1453,00 | FS |
| 1454,00 | FU |
| 1455,00 | FW |
| 1456,00 | FY |
| 1457,00 | GA |
| 1458,00 | GC |

| Lambda (nm) | ## |
|-------------|----|
| 1459,00 | GE |
| 1460,00 | GG |
| 1461,00 | GJ |
| 1462,00 | GL |
| 1463,00 | GN |
| 1464,00 | GQ |
| 1465,00 | GS |
| 1466,00 | GU |
| 1467,00 | GW |
| 1468,00 | GY |
| 1469,00 | HA |
| 1470,00 | HC |
| 1471,00 | HE |
| 1472,00 | HG |
| 1473,00 | HJ |
| 1474,00 | HL |
| 1475,00 | HN |
| 1476,00 | HQ |
| 1477,00 | HS |
| 1478,00 | HU |
| 1479,00 | HW |
| 1480,00 | HY |
| 1481,00 | JA |
| 1482,00 | JC |
| 1483,00 | JE |
| 1484,00 | JG |
| 1485,00 | JJ |
| 1486,00 | JL |
| 1487,00 | JN |
| 1488,00 | JQ |
| 1489,00 | JS |
| 1490,00 | JU |
| 1491,00 | JW |
| 1492,00 | JY |
| 1493,00 | KA |
| 1494,00 | KC |
| 1495,00 | KE |
| 1496,00 | KG |
| 1497,00 | KJ |
| 1498,00 | KL |
| 1499,00 | KN |
| 1500,00 | KQ |