

Transmission Laser Modules

Key Features

InGaAsP monolithically integrated DFB laser and modulator in-house chip

Low drive voltage ($\leq 2V_{pp}$)

Very low dispersion penalty up to 80 km for 10.7Gbit/s operation (up to 1600ps/nm)

XMD MSA compliant

FPC for electrical connections

RoHs compliant

Applications

STM-64 (Long-Haul) and OC-192 (Long-Reach) XFP Transceiver

For more Info

Please contact us at:

North America: 514.748.4848
888.922.1044

Europe & Asia: +33 (0) 1 69 80 58 33
or via e-mail at sales@3spgroup.com

1925 LMM

10 Gb/s Electro-Absorptive Integrated Laser Modulator Optical Sub-Assembly 1600 ps/nm – DWDM – LC Receptacle

This 1925 LMM contains a 3S PHOTONICS DFB laser with monolithically integrated electro-absorption modulator.

The modulation voltage is applied to the modulator section while the DFB laser operates CW. Without the complexity of LiNbO3 external modulators, the 1925 LMM is dedicated to STM64 / OC-192 bit rate with reduced size and cost. This device allows 10 Gbit/s data transmission in compliance with ITU-T standards.

The 1925 LMM is optimized for up to 10.7Gbit/s DWDM transmission systems supporting dispersion up to 1600 ps/nm.



**10 Gb/s Electro-Absorptive
Integrated Laser Modulator
Optical Sub-Assembly
1600 ps/nm – DWDM –
LC Receptacle**



OPTICAL CHARACTERISTICS

Table 1

Parameters	Symb	Test conditions	Min	Max	Units
Operating case temperature	T _c		-5	75	°C
Laser threshold current	I _{th}	VBM	5	35	mA
Laser operating current	I _{op}	VBM, T _{wave}	70	110	mA
Laser chip temperature range for tunability	T _{wave}		30	40	°C
Modulator bias voltage	VBM		-2	0	V
Modulator drive voltage	V _{pp}	Note 1		2.5	V _{pp}
Average optical output power	P _{AVE}	I _{op} , DER, λ _c , notes 1, 2	0	+4	dBm
Tracking Error	TE	T _{wave} , I _{op} , note 3	-0.5	+0.5	dB
Center wavelength range	λ _c	@ I _{op} , T _{wave}	1529.55	1563.86	nm
Wavelength tuning coefficient	Δλ/°C		80	100	pm/°C
Center wavelength tolerance BOL	ΔλBOL	@ I _{op} , T _{wave} , BOL	-20	+20	pm
Center wavelength tolerance EOL	ΔλEOL	@ I _{op} , T _{wave} , 15 years	-100	+100	pm
Center wavelength drift with Case Temperature	Δλ/ΔT _c	T _c =[-5;75]°C @T _{wave}	-0.5	+0.5	pm/°C
Center wavelength drift with laser current	Δλ/ΔI	@ T _{wave} , VBM	4	15	pm/mA
Side Mode Suppression Ratio	SMSR	Note 1	35		dB
Linewidth	Δλ	@3dB FWHM, CW, I _{op}		15	MHz
Relative Intensity Noise	RIN	100 MHz to 9 GHz, @ P _{ave}		-135	dB/Hz
Dynamic Extinction Ratio BOL	DER	I _{op} , Note 1, 2,	9.5		dB
Dispersion penalty	ΔS	DER, Note 1, 2, 4		2	dB
		DER, Note 1, 2, 5		3	dB
Monitor diode current	I _m	I _{op} , V=-5V	50	1000	μA
Dark current	I _d			0.1	μA
TEC current	I _t	PAVE op, VBM op, I _{op} , ΔT=75°C-T _{wave}		1.3	A
TEC voltage	V _t			2.3	V
TEC power	WTEC	PAVG op, VBM op, I _{op} , ΔT=75°C-T _{wave}		1.5	W
Thermistor resistance	RTH	T _s =25°C	9.5	10.5	KΩ
Thermistor β coefficient	β	T _s =25°C	3800	4000	K

Note 1 : tested @BER= 10-10, 10.7Gb/s, modulation, 231-1 PRBS, NRZ line code, driver OKI 4145KW

Note 2 : 1600 ps/nm minimum dispersion @ 1550nm. An APD-TIA receiver with sensitivity better than -25 dBm BER 1E-10 in Back to Back is used.

Note 3 : TE =|[P(75°C)-P(T_{wave})|/P(T_{wave})|

Note 4 : wavelength range [1529.55;1560.61] nm

Note 5 : wavelength range [1561.42;1563.86] nm

ABSOLUTE MAXIMUM RATINGS

Table 2

Exposure to absolute maximum rating conditions for extended periods may affect device reliability.

Parameters	Min	Max.	Unit
Storage case temperature	-40	+85	°C
Laser Forward Current		150	mA
Laser Reverse Voltage		2	V
Laser Reverse Current		10	μA
Modulator Forward Voltage		1	V
Modulator Forward Current		100	mA
Modulator Reverse Voltage		5	V
Modulator Reverse Current		10	μA
Photodiode Forward Current		1	mA
Photodiode Reverse Voltage		20	V
TEC Voltage		2.6	V
TEC Current		1.3	A
Flex pad soldering Temperature (5s)		290	°C
Flex pad allowed soldering rework		1	time
Flex torsion angle	-10	10	°
Flex (FPC) bending radius	2		mm

10 Gb/s Electro-Absorptive
Integrated Laser Modulator
Optical Sub-Assembly
1600 ps/nm – DWDM –
LC Receptacle

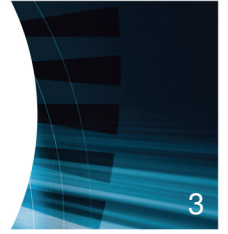

MECHANICAL DETAILS

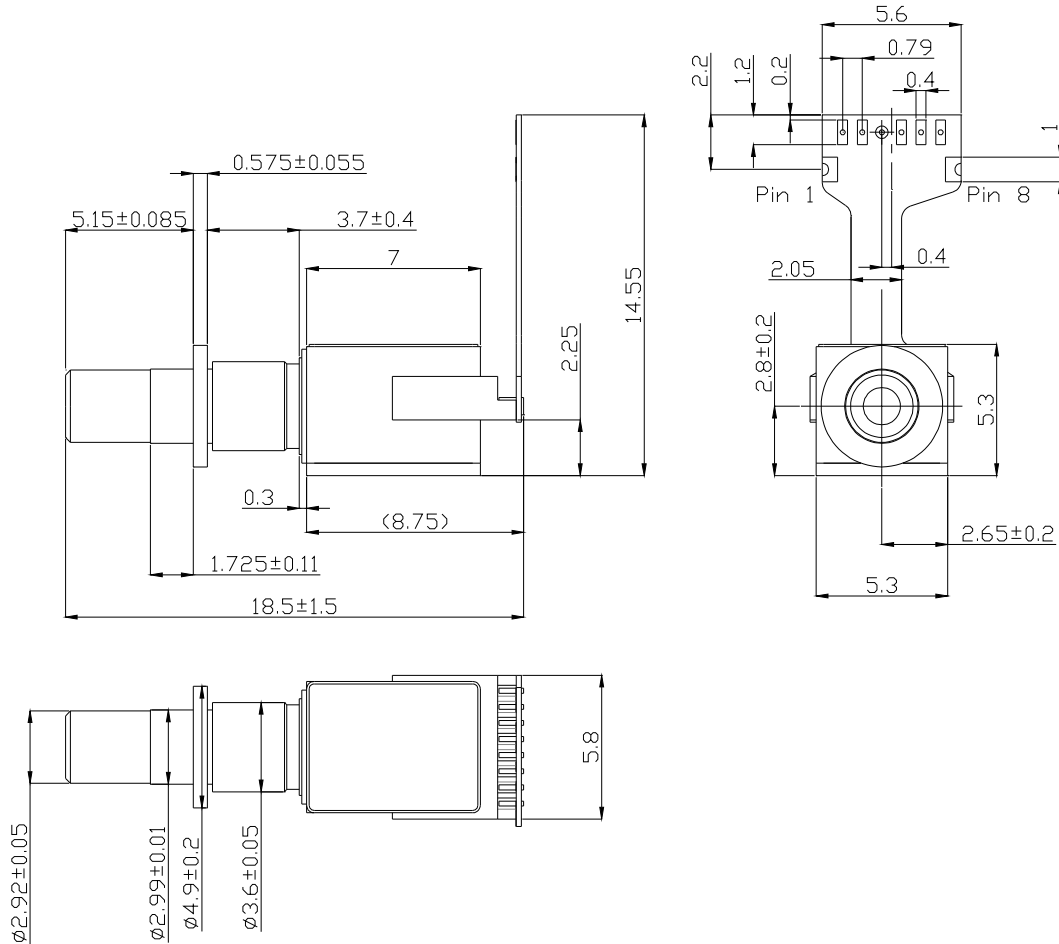

PIN OUT

N°	Description
1	TE Cooler Cathode
2	TE Cooler Anode
3	Floating signal ground
4	Modulator Anode (bias-)
5	Floating signal ground
6	PD Anode (bias-)
7	LD Anode (bias-)
8	Thermistor

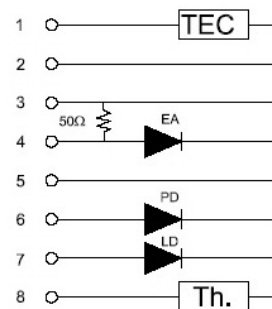

**10 Gb/s Electro-Absorptive
Integrated Laser Modulator
Optical Sub-Assembly
1600 ps/nm – DWDM –
LC Receptacle**

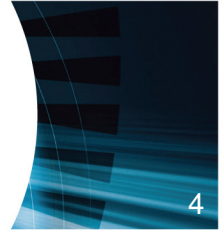

SHIPMENT PACKING

Each device is individually packed in an anti-static container and in such a manner as to prevent damage in transit.

The packing shall include the following information:

3S PHOTONICS logo

Product family name : 1925 LMM

Product code : 3CN number (see Ordering information section)

Serial number

Hazard warning label (ESD)

Laser Safety Class Label

DELIVERABLE DATA

The following data shall be supplied with each device under EDF format:

lth, lmon, lt, vt, pt, lf, tlaser, pave, DER, DS, Driver Modulation Voltage, Driver Offset Voltage, Driver Eye Crossing Voltage

LASER SAFETY INFORMATION

Take appropriate precautions to prevent undue exposure to naked eye.

This product is classified Class 1M Laser Product according to IEC-60825-1: edition2.

All versions are Class IIIB laser products per 21 CFR 1040-10 Laser. Safety requirements under accession number 0120546-00.

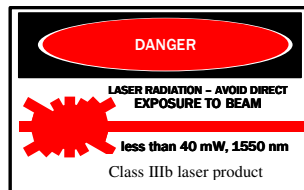

HANDLING

This product is sensitive to electrostatic discharge and should not be handled except at a static free workstation. Take precautions to prevent ESD; use wrist straps, grounded work surfaces and recognized anti-static techniques when handling the module.

Handle the PD module by its package only, never hold it by its receptacle.

Care should be taken to avoid supply transient and over voltage. Over voltage above the maximum specified in absolute maximum rating section may cause permanent damage to the device.

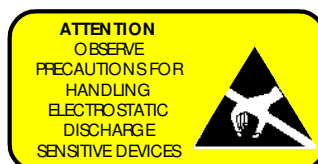

1925 LMM



10 Gb/s Electro-Absorptive
Integrated Laser Modulator
Optical Sub-Assembly
1600 ps/nm – DWDM –
LC Receptacle

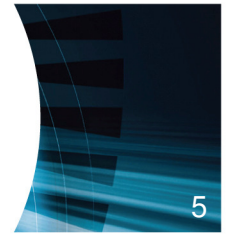
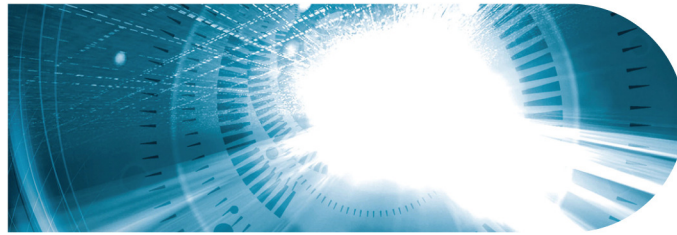

ORDERING INFORMATION

1925 LMM
LC receptacle – FPC

Application	Part number	Output Power	Case Temperature
1600 ps/nm – DWDM	3CN01632##	[0, +4] dBm	Commercial

defines the wavelength according to the Table 3.

Table 3

λ (nm)	THz	Code ##	λ (nm)	THz	Code ##
1529,55	196,00	BP	1546,92	193,80	DK
1530,33	195,90	BR	1547,72	193,70	DM
1531,12	195,80	BT	1548,51	193,60	DP
1531,90	195,70	BV	1549,32	193,50	DR
1532,68	195,60	BX	1550,12	193,40	DT
1533,47	195,50	BZ	1550,92	193,30	DV
1534,25	195,40	CB	1551,72	193,20	DX
1535,04	195,30	CD	1552,52	193,10	DZ
1535,82	195,20	CF	1553,33	193,00	EB
1536,61	195,10	CH	1554,13	192,90	ED
1537,40	195,00	CK	1554,94	192,80	EF
1538,19	194,90	CM	1555,75	192,70	EH
1538,98	194,80	CP	1556,56	192,60	EK
1539,77	194,70	CR	1557,36	192,50	EM
1540,56	194,60	CT	1558,17	192,40	EP
1541,35	194,50	CV	1558,98	192,30	ER
1542,14	194,40	CX	1559,79	192,20	ET
1542,94	194,30	CZ	1560,61	192,10	EV
1543,73	194,20	DB	1561,42	192,00	EX
1544,53	194,10	DD	1562,23	191,90	EZ
1545,32	194,00	DF	1563,05	191,80	FB
1546,12	193,90	DH	1563,86	191,70	FD

All wavelengths referenced to vacuum, Twave for WDM applications.

Revised September 2013

Please note: information in this document is typical and must be specifically confirmed in writing by your supplier before it becomes applicable to any order or contract. Information is subject to change without notice.
©2011 3S PHOTONICS S.A.S

ORDERING INFO

Please contact your Sales Manager. 3SPGroup can also develop custom products to meet a wide range of technical requirements.

3SPGroup

North America: 514.748.4848
888.922.1044

Europe and Asia: +33 (0)1 69 80 58 33
www.3spgroup.com • sales@3spgroup.com

