

## Active Components Pump Laser Modules

### Key Features

- Up to 950 mW operating power
- Operating temperature up to 75 °C
- Fiber Bragg Grating (FBG) on PMF
- Telcordia GR-468-CORE qualified
- RoHS compliant

### Applications

- High output power low noise Erbium-Doped Fiber Amplifier
- Multi-pumping architectures
- Sensors
- CATV
- Fiber Lasers

### For more Info

Please contact us at:  
 Europe & Asia: +33 169 805 833  
 North America: +1 514 748 4848  
 +1 888 922 1044  
[sales@3spgroup.com](mailto:sales@3spgroup.com)

## 2000CHP

### 1050 mW Kink-Free, FBG Stabilized, 980 nm Cooled Pump Laser Module

The 2000CHP is a new generation of 980 nm terrestrial pump modules powered by in-house chip technology fully qualified for submarine applications, ensuring an outstanding level of performance, power consumption and reliability.

Low Profile, 14-pin butterfly modules are available with an operating power up to 950 mW.

They incorporate a thermoelectric cooler (TEC), a precision NTC thermistor and a back-facet monitoring photodiode.

The wavelength is “locked” utilizing a fiber bragg grating (FBG) located in a single mode Polarization Maintaining Fiber (PMF) pigtail.

The module meets the Telcordia™ GR-468-Core requirements for hermetic 980 nm pump modules.

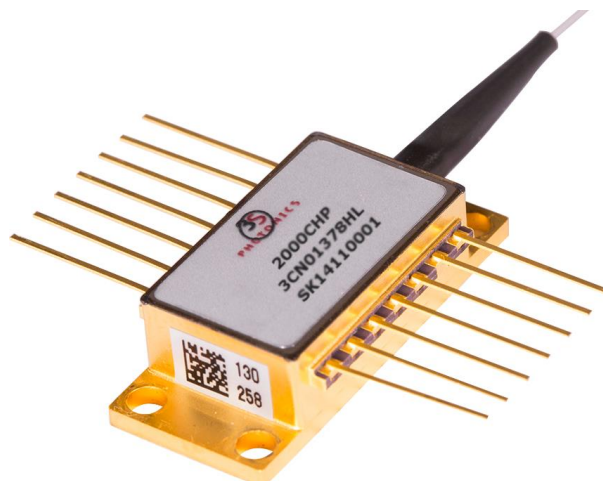

**1050 mW Kink-Free,  
FBG Stabilized,  
980 nm Cooled  
Pump Laser Module**

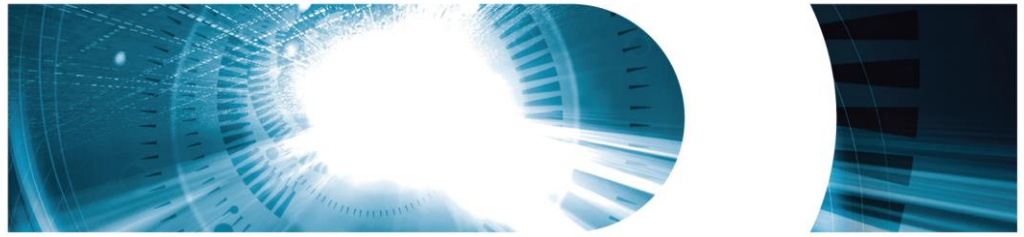

## ELECTRO-OPTICAL CHARACTERISTICS

The following parameters are specified BOL for a  $T_{\text{case}} = -5\text{ °C}$  to  $75\text{ °C}$ ,  $V_{\text{BFM}} = -5\text{ V}$  and  $-50\text{ dB}$  max back-reflection unless otherwise stated.

Parameters	Conditions	Symbol	Min	Typ	Max	Unit
<b>PUMP LASER</b>						
Threshold current <sup>(1)</sup>		$I_{\text{th}}$	-	80	100	mA
Nominal operating power		$P_{\text{nom}}$	850	-	-	mW
Kink free power <sup>(2)</sup>		$P_{\text{kink}}$	$1.1 \times P_{\text{nom}}$	-	-	mW
Forward current <sup>(3)</sup>	$P_{\text{nom}} = 800\text{ mW}$	$I_{\text{nom}}$	-	-	1450	mA
	$P_{\text{nom}} = 850\text{ mW}$		-	-	1500	
	$P_{\text{nom}} = 900\text{ mW}$		-	-	1650	
	$P_{\text{nom}} = 950\text{ mW}$		-	-	1650	
Forward voltage	@ 950 mW	$V_{\text{nom}}$	-	-	2.4	V
Peak wavelength tolerance	@ $T_{\text{case}} = T_{\text{FBG}} = 25\text{ °C}$ $0.1 \times P_{\text{nom}}$ to $P_{\text{nom}}$	$\Delta\lambda_{\text{p}}$	-	-	$\pm 1$	nm
Wavelength tuning vs temperature ( $T_{\text{grating}} = -5$ to $75\text{ °C}$ )	$0.1 \times P_{\text{nom}}$ to $P_{\text{nom}}$	$\Delta\lambda_{\text{p}} / \Delta T$	-	-	0.02	nm / °C
Spectral width @ -3 dB	$0.1 \times P_{\text{nom}}$ to $P_{\text{nom}}$	$\Delta\lambda_{\text{FWHM}}$	-	-	1.0	nm
Power in band <sup>(4)</sup>	$P_{\text{nom}}$	$P_{\text{band}}$	90	-	-	%
Optical power stability	Peak to peak, 10 Hz-50 kHz, 60 sec, $P_{\text{nom}}$	$\Delta P$	-	-	2	%
<b>MONITOR DIODE</b>						
Responsivity		$I_{\text{BFM}} / P$	0.5	-	10	$\mu\text{A} / \text{mW}$
Dark current	$V_{\text{r}} = 5\text{ V}$	$I_{\text{BFM\_dark}}$	-	-	100	nA
<b>THERMO-ELECTRICAL COOLER</b>						
Cooling capacity		$\Delta T_{\text{TEC}}$	50	-	-	°C
TEC voltage (EOL)	$T_{\text{case}} = 75\text{ °C}$ , $1.1 \times I_{\text{nom}}$ @950mW	$V_{\text{TEC, EOL}}$	-	-	4.0	V
TEC current (EOL)	$T_{\text{case}} = 75\text{ °C}$ , $1.1 \times I_{\text{nom}}$ @950mW	$I_{\text{TEC, EOL}}$	-	-	3.0	A
<b>THERMISTOR</b>						
Resistance	25 °C	$R_{\text{th}}$	9.5	10	10.5	k $\Omega$
Constant		B	3600	-	4200	K

(1)  $I_{\text{th}}$  is the intersection point with the x-axis of a linear fit of the P(I) curve between 15 mW and 50 mW

(2) A kink is detected when the local slope  $dP/dI$  is below  $S_{\text{min}}$  or above  $S_{\text{max}}$ .  $S_{\text{min}}$  is defined as  $0.5 \times S_{\text{avg}}$  and  $S_{\text{max}}$  is defined as  $1.5 \times S_{\text{avg}}$

(3) EOL forward current  $I(\text{EOL}) = 1.1 \times I(\text{BOL})$

(4)  $P_{\text{band}}$  is defined as the power within the band  $\lambda_{\text{p}} \pm 1.5\text{ nm}$  vs the total output power

**1050 mW Kink-Free,  
FBG Stabilized,  
980 nm Cooled  
Pump Laser Module**

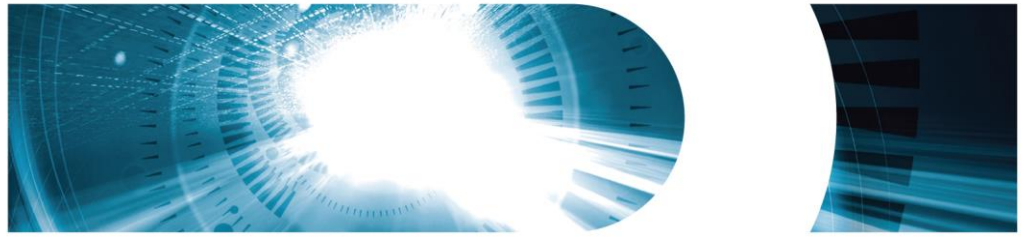

## ABSOLUTE MAXIMUM RATINGS

Exposing this device to stresses and conditions above those listed in this section could cause permanent damage and affect reliability. The device is not meant to operate outside the operational limits described in previous section at any length of time.

Parameter Conditions	Symbol	Min	Max	Unit
Storage temperature (2000 h)	$T_{stg}$	-40	85	°C
Operating temperature ( $T_{submount} = 25\text{ °C}$ )	$T_{op}$	-5	75	°C
Lead soldering temperature (10 s maximum)		-	280	°C
LD forward drive current (10 s maximum)	$I_{f\_max}$	-	1700	mA
LD reverse voltage	$V_{r\_max}$	-	2.5	V
PD reverse voltage	$V_{PD\_max}$	-	15	V
PD forward current	$I_{PD\_max}$	-	10	mA
TEC voltage	$V_{TEC\_C\_max}$	-	4.2	V
TEC current	$I_{TEC\_C\_max}$	-	3.2	A
ESD* damage	$V_{ESD}$	-	1000	V
Mounting torque		-	150	mN.m
Fiber bend radius		20	-	mm
Axial pull force (1x1min)		-	5	N

\* Human Body model, C = 100 pF, R = 1.5 kΩ

## FIBER PIGTAIL CHARACTERISTICS

Parameter	Note	Min	Typ	Max	Unit
Fiber type		SM98-PS-U25A-H or equivalent			
Coating diameter	(except along grating)	230	250	270	μm
FBG recoat diameter		-	-	400	μm
FBG position	Module to center of FBG	-	3	-	m
Loose tube buffer diameter		885	-	915	μm
Fiber proof test level		200	-	-	kpsi
Grating proof test level		150	-	-	kpsi
Pigtail termination	Bare fiber				
Polarization State	Aligned parallel to the slow axis				

**1050 mW Kink-Free,  
FBG Stabilized,  
980 nm Cooled  
Pump Laser Module**

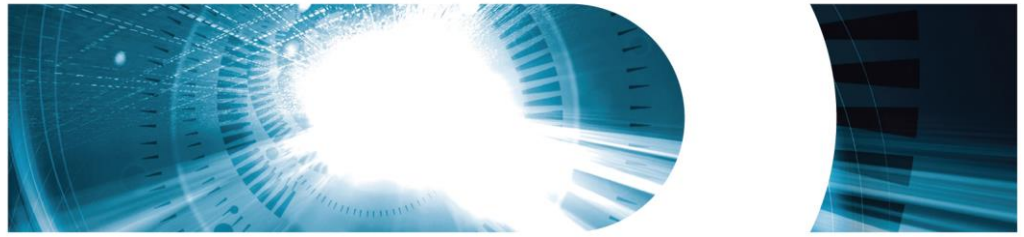

## MECHANICAL DETAILS

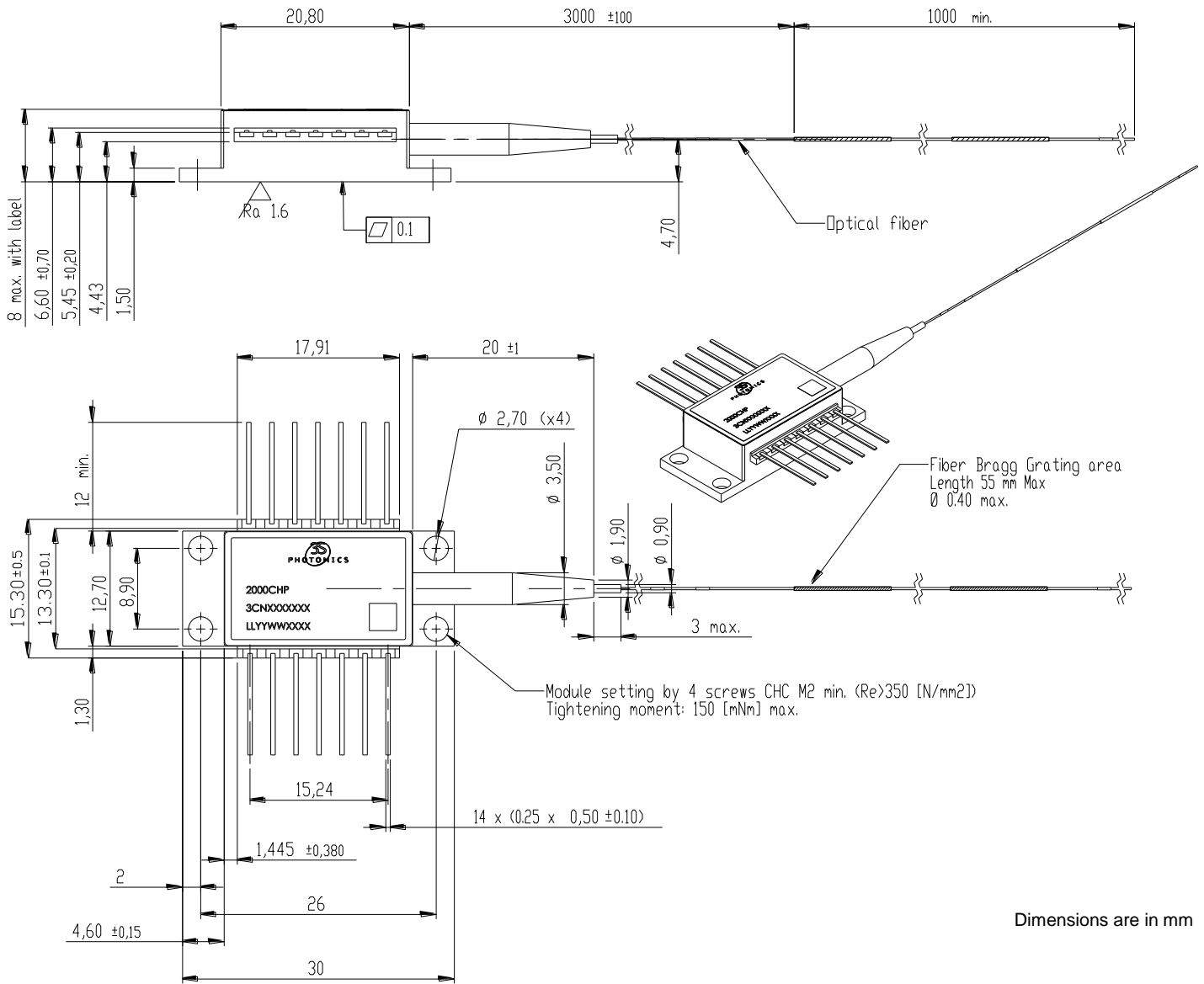

## PIN ASSIGNMENT

N°	Description	N°	Description
1	TEC (+)	8	No connect
2	Thermistor	9	No connect
3	Monitor PD Anode	10	Laser Anode (+)
4	Monitor PD Cathode	11	Laser Cathode (-)
5	Thermistor	12	No connect
6	No connect	13	Ground
7	No connect	14	TEC (-)

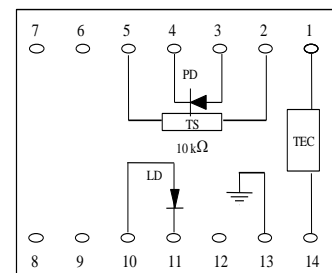

Totally floating pin-out

# 2000CHP



1050 mW Kink-Free,  
FBG Stabilized,  
980 nm Cooled  
Pump Laser Module

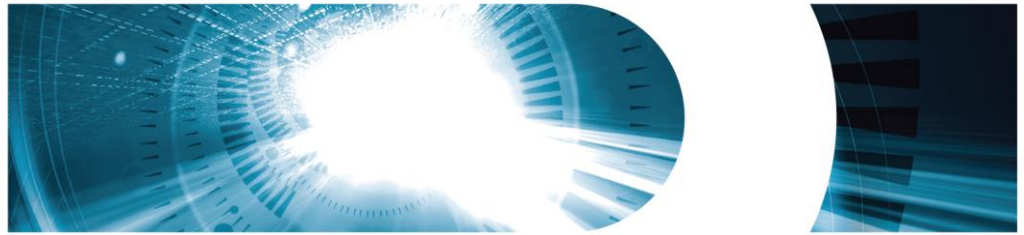

## LASER SAFETY INFORMATION

This laser module emits invisible light. Take appropriate precautions to prevent undue exposure to naked eye when module is in operation. This product is classified Class 4 Laser Product according to IEC-60825-1.

## HANDLING

This product is sensitive to electrostatic discharge and should not be handled except at a static free workstation. Take precautions to prevent ESD; use wrist straps, grounded work surfaces and recognized anti-static techniques when handling the pump laser module. Caution! Handle the module by its package only; never hold it by its pigtail. Care should be taken to avoid supply transient currents and voltages. Drive voltage above the maximum specified in absolute maximum rating section may cause permanent damage to the device.

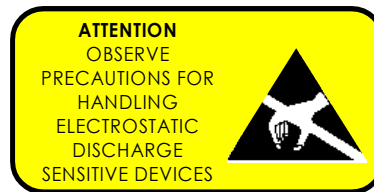

## APPLICATION NOTE

In order to prevent any mishandling, misuse, neglect or accident, it is highly recommended to read and follow the instructions detailed in the application note:

[RCL IMA APN 000 00007 "Handling, Mounting, Testing and Operating Cooled 14-pin Butterfly Laser Pumps"](#)

## ORDERING INFORMATION

### 2000CHP PUMP PRODUCT FAMILY

PMF Pigtail	$\lambda_p = 974.0 \text{ nm}, T = 25 \text{ }^\circ\text{C}$	$\lambda_p = 976.0 \text{ nm}, T = 25 \text{ }^\circ\text{C}$	$\lambda_p = 979.5 \text{ nm}, T = 25 \text{ }^\circ\text{C}$
Nominal Power	Part Number	Part Number	Part Number
800 mW	3CN01466HA	3CN01378HA	3CN01376HA
850 mW	3CN01466HL	3CN01378HL	3CN01376HL
900 mW	3CN01466JA	3CN01378JA	3CN01376JA
950 mW	3CN01466JL	3CN01378JL	3CN01376JL

3SPGroup can also develop custom products to meet a wide range of technical requirements. Please contact your Sales Manager for details.

# 2000CHP

1050 mW Kink-Free,  
FBG Stabilized,  
980 nm Cooled  
Pump Laser Module

**3SP**Group

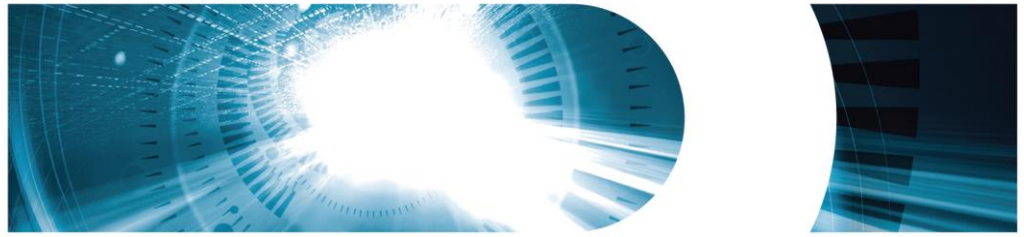

## CONTACT INFORMATION

Europe & Asia: +33 169 805 833  
North America: +1 514 748 4848  
+1 888 922 1044

[sales@3spgroup.com](mailto:sales@3spgroup.com)  
[www.3spgroup.com](http://www.3spgroup.com)

## IMPORTANT NOTICE

Information in this document is typical and must be specifically confirmed in writing by your supplier before it becomes applicable to any order or contract.

Information is subject to change without notice.

## NOTES