

ITF TECHNICAL NOTE

Rules of thumb for DCF fiber

The Fluoroacrylate (FA) layer of dual core fiber (DCF) fibers is soft and does not adhere strongly to surrounding layers. In order to manufacture components with DCF output fibers, we need to form anchor bonds onto the FA fiber coating. A study has been performed to evaluate the strength of components utilizing such fibers. The conclusions are that the components are robust, however the precautions below need to be observed.

Maximum loads to be applied to the DCF pigtail:

- Maximum tension : 252g (1/2 lbs)
- Maximum torsion: 0.225°/mm of fiber under torsion (ie 45° per 200mm)
- Maximum operating temperature: 70°C
- The above limits apply at the worst case temperature of 70°C, the jacket strength increases as temperature reduces.

This applies to any DCF fiber of the component in any of the packages, high or low power.

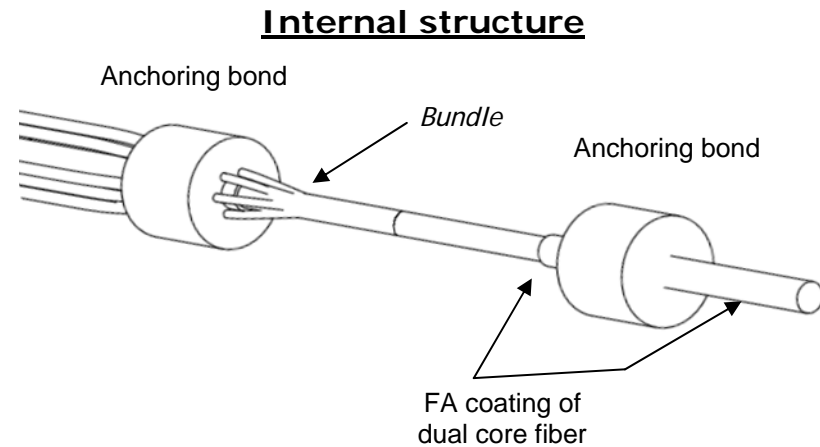

High power package

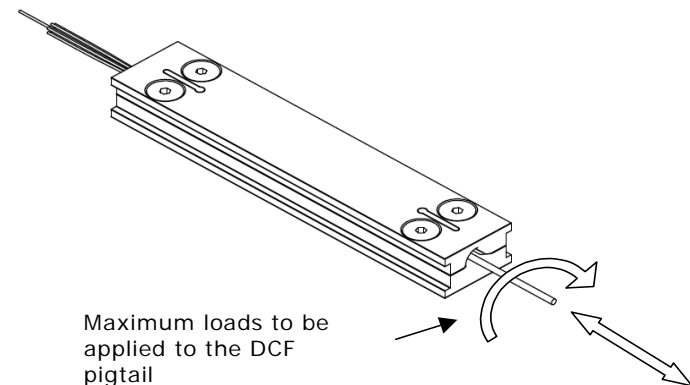

Montreal, January 2, 2008